

# BAXI

## Range Guide



**A** >90%



# Introduction

At Baxi, we know a lot about how people react to heat. We've been at the heart of people's homes for over a century and a half. But while our products respond to people's need for warmth and wellbeing, it's how Baxi responds to other needs that is just as important.

We're committed to the requirements of our installers and the service they offer, providing them with the right products and support.

Our highly efficient boiler range – Baxi Platinum Combi HE A, Baxi Duo-tec Combi HE A, Baxi Solo HE A and Baxi Megaflo System HE A – consists of the most energy efficient models available, exceeding the Government's minimum standards and carrying a SEDBUK 2005 Band A (>90%) rating. With a choice of models suitable for all situations.

Nobody wants global warming. But everybody wants to keep warm. As leaders in heating innovation, we realised the need to move towards renewable energy sources some time ago. As a result, we also have a comprehensive range of low and zero carbon heating systems available - encompassing solar energy, air source heating, ground source heating, combined heat and power and naturally-based biomass fuels.

Our boilers are among the most efficient available, designed to be easy to install, reliable and economical.

We've invested over £2million in our new Product Design Centre, where each component is thoughtfully tested to make sure every Baxi product has a long and efficient life. With the support and service you'd expect from one of Britain's leading heating appliance manufacturers, it makes your life easier too.



# Contents



Baxi Platinum  
Combi HE A

The Baxi Platinum Combi HE A range offers an industry leading 5 year parts and labour warranty\*. Available in 24kW, 28kW, 33kW and 40kW outputs with hot water flow rates of up to 16 l/min at 35°C rise.

PAGE 4



Baxi Duo-tec  
Combi HE A

Through continued product development, Baxi has produced the Baxi Duo-tec Combi HE A with 24kW, 28kW, 33kW and 40kW outputs. All with a 2 year parts and labour warranty\*.

PAGE 7



Baxi Solo  
HE A

Baxi Solo HE A boilers are small in size but big in performance incorporating 12kW, 15kW, 18kW, 24kW and 30kW outputs. All with a 2 year parts and labour warranty\*.

PAGE 10



Baxi Megaflö  
System HE A

The Megaflö System HE A, available in 15kW, 18kW, 24kW, 28kW and 32kW outputs, is the perfect choice for a range of applications. All with a 2 year parts and labour warranty\*.

PAGE 13



Baxi Bermuda  
BBU HE

The Baxi Bermuda BBU HE is the only replacement high efficiency back boiler in the UK and comes with a 2 year parts and labour warranty\*.

PAGE 16



Baxi Solarflö™

The Baxi Solarflö™ system uses the Sun's solar energy to provide domestic hot water and comes with a 10 year warranty on the flat plate collectors, 5 year warranty on evacuated tube collectors and 2 year warranty on components\*.

PAGE 26



Baxi Ambiflö™

Baxi Ambiflö™ is an air to water heat pump, providing central heating for domestic properties and comes with 1 year warranty\*.

PAGE 27



Baxi Geoflö™

The Baxi Geoflö™ is a ground source heat pump system. It works by tapping into the natural heat found just metres below the Earth's surface and comes with a 1 year warranty\*.

PAGE 28



Baxi Biomass  
Solid Fuel Heating

Baxi Biomass boilers use carbon neutral fuel such as pellets or logs from regenerated sources to provide sustainable and environmentally friendly heat for the home and comes with 1 year warranty\*.

PAGE 29



Baxi Combined  
Heat & Power

Generating electricity as well as heat, the Baxi DACHS mini-CHP is widely used as a more energy efficient way to heat and power buildings, with less reliance upon centralised power generation.

PAGE 30



Help is always on hand from **heateam**, the service division of Baxi Group. Offering after sales support for all Baxi Group products, **heateam** has 280 Gas Safe Registered engineers nationwide.



PAGE 31

## Training

We offer training to the highest standards and our expertise is available nationwide.

PAGE 31



It's certainly rare to find optimum performance, reliability and such intelligent design features in one boiler. And rarer still to find it backed by an industry-leading 5 year parts and labour warranty\*. But that's exactly what the Baxi Platinum Combi HE A range offers.

It uses Baxi's proven boiler technology, tested in our new state-of-the-art facility for reliability. It has an intelligent control system to automatically adjust heat output, and provides maximum heating and hot water performance with minimum running costs - gaining a SEDBUK Band A rating - taking efficiency to a new level.

## Key features & benefits:

- 5-year parts and labour warranty\* giving customers complete peace of mind through **heateam**
- SEDBUK 2005 Band A (>90%) rated

- Available in four outputs, 24kW, 28kW, 33kW and 40kW, this modulating boiler fits most size systems
- Exceptional hot water flow rates from 9.8l/min to 16.4l/min, suitable for larger properties
- Supplied with pre-plumbing jig for easier and labour saving installation
- 1 metre flying lead for easy electrical connection to a 3amp plug
- Extensive flue options with flue lengths up to 20 metres for easier and flexible siting. Telescopic flue available for quick installation
- Built in filling loop to save time and be aesthetically pleasing
- A separate temperature control for central heating and domestic hot water to manage water pressure safety
- Built in frost thermostat for flexibility of siting
- Suitable for use with the Multifit GasSaver, which can give annual gas savings on DHW of up to 37% over a SEDBUK band A boiler (see page 24)



\*Subject to registration and an annual service



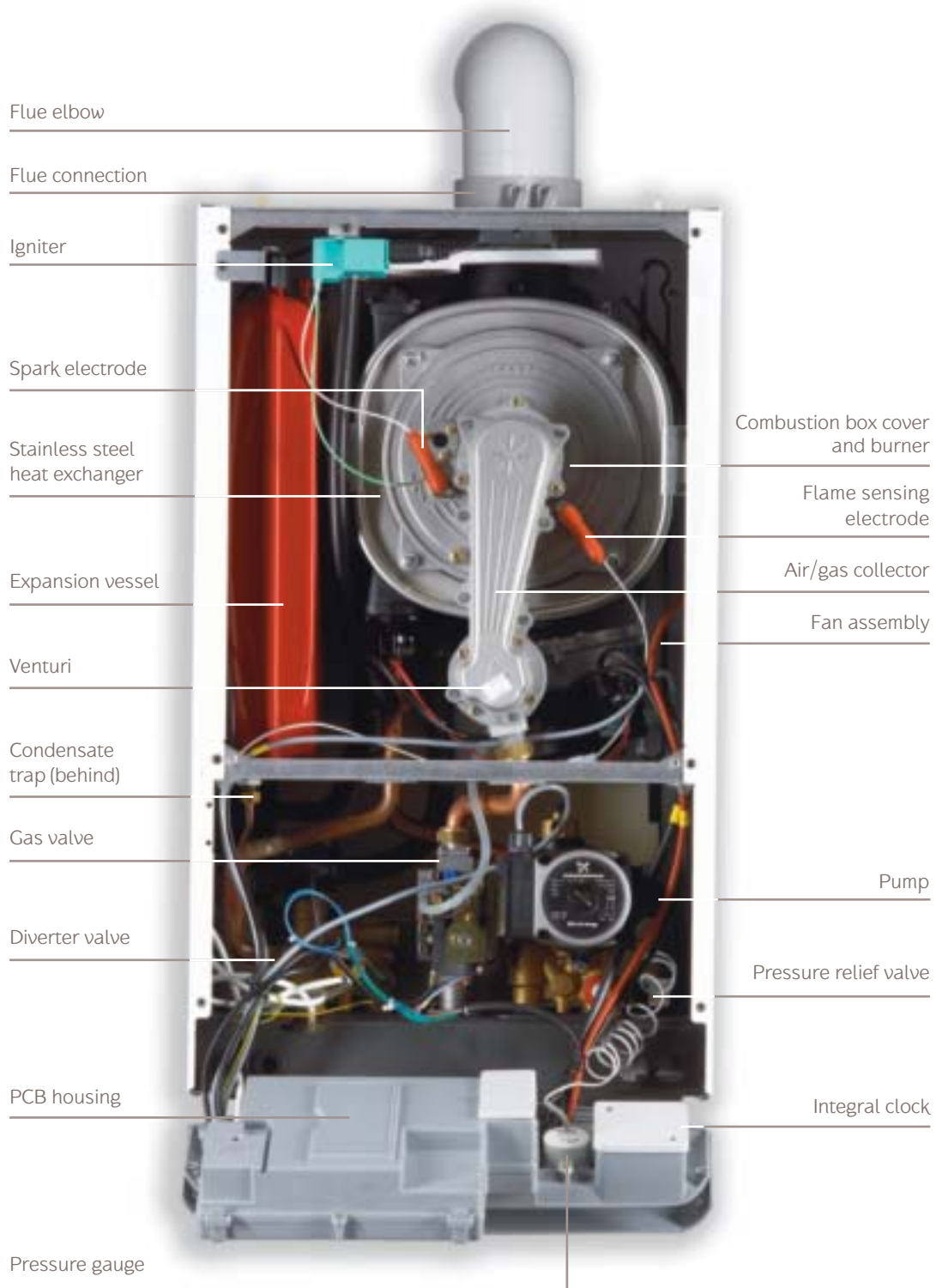

Fully modulating outputs



SEDBUK 2005 Band A (>90%)



Timer as standard



Ultra low NO<sub>x</sub> emissions class 5 - helping to protect the environment



Can be located in unventilated cupboards or compartments



Exceptional flow rates up to 16 l/min at 35°C temp rise





# Platinum Combi HE A

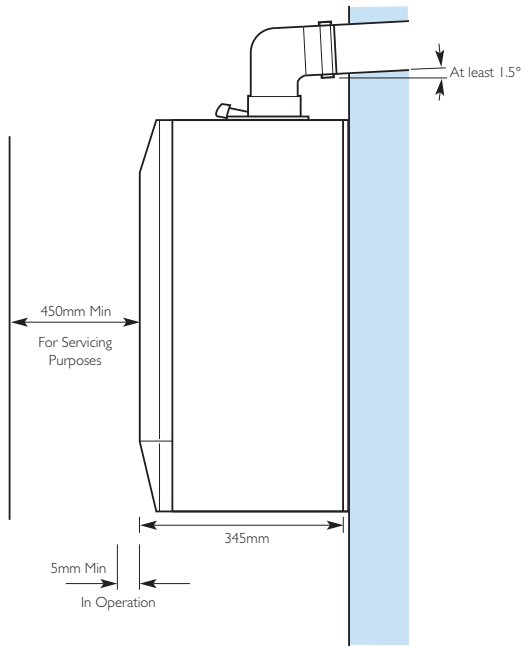
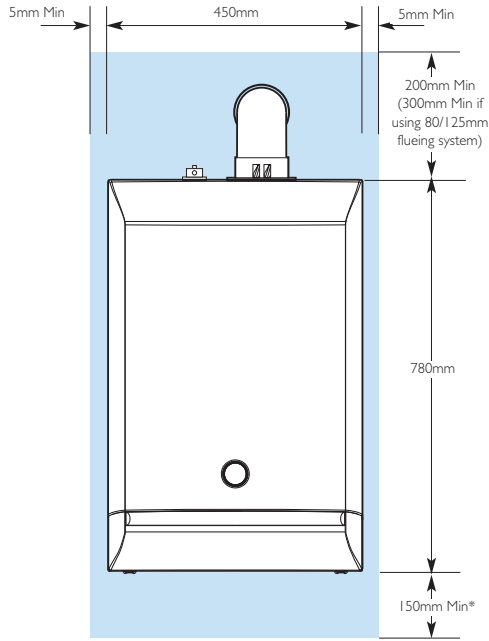

\* This is the MINIMUM recommended dimension. Greater clearance will aid installation and maintenance.

## Baxi Platinum Combi HE A Series: Wall mounted high efficiency combination boilers

		24 HE A	28 HE A	33 HE A	40 HE A
<b>CONTROLS</b>					
Concealed User Controls		Yes	Yes	Yes	Yes
On/Off Switch with Reset		Yes	Yes	Yes	Yes
User Adjustable DHW Temperature		Yes	Yes	Yes	Yes
User Adjustable CH Temperature		Yes	Yes	Yes	Yes
LED Temp/Status/Fault Diagnosis Display		2 digits/3 LEDs	2 digits/3 LEDs	2 digits/3 LEDs	2 digits/3 LEDs
Integral 24 hour Electro-mechanical Timer		Fitted as standard	Fitted as standard	Fitted as standard	Fitted as standard
<b>GAS</b>					
Gas Supply Pipe Size	mm	22	22	22	22
Natural Gas		Yes	Yes	Yes	Yes
LPG (Butane/Propane)		No	No	No	No
Nominal Inlet Supply Pressure	mbar	20	20	20	20
Maximum Gas Rate	m <sup>3</sup> /hr	2.61	3.10	3.6	4.36
Heat Input Central Heating	kW Max Gross	22.7	27.4	32.1	36.4
	kW Max Net	20.5	24.7	28.9	32.8
	kW Min Gross	7.8	10	10.8	11
	kW Min Net	7.0	9.0	9.7	9.9
Heat Output CH Non Condensing (70° Mean Water temp)	kW Max	20	24	28	32
	kW Min	6.8	8.7	9.4	9.6
Heat Output CH Condensing (40° Mean Water temp)	kW Max	21	25.9	30.3	34.4
	kW Min	7.4	9.5	10.2	12.1
Heat Input Domestic Hot Water (DHW)	kW Max Gross	27.4	32.1	37.7	45.7
	kW Max Net	24.7	28.9	34	41.2
Heat Output Domestic Hot Water	kW Max	24	28	33	40
Maximum Domestic Hot Water Flow Rate	l/min @ 35°C Rise	9.8	11.5	13.5	16.4
Seasonal Efficiency	%	91.1	91.1	91.1	91.1
SEDBUK Rating Band		A	A	A	A
NO <sub>x</sub> Class		5	5	5	5
NO <sub>x</sub> Levels	mg / kWhr	22.3	26.0	21.8	25.2
<b>ELECTRICAL</b>					
Electrical Supply	Volts / Hz	230V / 50Hz	230V / 50Hz	230V / 50Hz	230V / 50Hz
Permanent Live Required		Yes	Yes	Yes	Yes
Fitted Electrical Cable		1m x 3 core x 0.75mm <sup>2</sup>			
Power Consumption	Watts	155	155	160	160
External Fuse Rating	Amps	3	3	3	3
Internal Fuse Rating	Amps	F2L	F2L	F2L	F2L
Ingress Protection Rating (without electro-mechanical timer fitted)		IPX 5D	IPX 5D	IPX 5D	IPX 5D
24 hour Pump Exercise		Yes	Yes	Yes	Yes
Pump Overrun		Yes	Yes	Yes	Yes
Integral 'Boiler Only' Frost Thermostat		Yes	Yes	Yes	Yes
<b>MECHANICAL &amp; HYDRAULIC</b>					
Compartment Ventilation Requirement		None	None	None	None
Pre-plumbing/Wall Mounting Jig		Yes	Yes	Yes	Yes
Flow & Return Pipe Size	mm	22	22	22	22
Condensate Discharge Pipe Size	mm	21.5	21.5	21.5	21.5
Integral Automatic Bypass		Yes	Yes	Yes	Yes
Min Domestic Hot Water Flow Rate	l/min	2	2	2	2
Min Domestic Hot Water Operating Pressure	bar	0.15	0.15	0.15	0.15
Maximum DHW System Pressure	bar	8	8	8	8
Safety Discharge Pressure	bar	3	3	3	3
Integral Expansion Vessel Capacity	litres	8	8	10	10
Max Capacity of Central Heating System	litres	125	125	155	155
Temporary Filling Loop included		Yes	Yes	Yes	Yes
CH System Inhibitor Required		Hard Water only			
<b>CONCENTRIC FLUE SYSTEM</b>					
Standard Telescopic Horizontal Flue Kit Length	mm	315 - 500	315 - 500	315 - 500	315 - 500
Max Equiv Length Horizontal/Vertical (60/100mm)	m	10	10	10	10
Max Equiv Length Horizontal/Vertical (80/125mm)	m	20	20	20	20
Equivalent Length per 135° Bend	m	0.5	0.5	0.5	0.5
Equivalent Length per 93° Bend	m	1	1	1	1
<b>TWIN PIPE FLUE SYSTEM</b>					
Diameters	mm	80 / 80	80 / 80	80 / 80	80 / 80
Max Equiv Length Horizontal/Vertical (parallel pipes)	m	15/15	15/15	15/15	15/15
Equivalent Length per 135° Bend	m	0.25	0.25	0.25	0.25
Equivalent Length per 91.5° Bend	m	0.5	0.5	0.5	0.5
<b>WEIGHTS</b>					
Max Installation Lift Weight	kg	43.6	44.2	45	45
Gross Packaged Boiler Weight	kg	48.6	49.2	50	50



Taking proven combi boiler technology and constantly developing it has produced the Baxi Duo-tec Combi HE A.

Its compact case dimensions and 100mm diameter standard flue make fitting it in confined spaces a breeze. Copper tails for water and gas connections, and isolating valves mounted on a pre-plumbing jig make installation even easier.

We've given all four Baxi Duo-tec Combi HE A models an easy to read pressure gauge.

Not only will customers love the look of the Baxi Duo-tec Combi HE A, they'll also love its energy efficiency.

## Key features & benefits:

- 2-year parts and labour warranty\* giving customers complete peace of mind through our **heateam**
- SEDBUK 2005 Band A (>90%) rated
- Available in four outputs 24kW, 28kW, 33kW and 40kW, this modulating boiler fits most sized systems. 24kW, 28kW and 33kW are also available as LPG models

- Exceptional hot water flow rates from 9.8l/m to 16.4l/min, suitable for larger properties
- Supplied with pre-plumbing jig for easier and labour saving installation
- Telescopic horizontal flue available for quick installation
- Built in filling loop to save time and be aesthetically pleasing
- A separate temperature control for central heating and domestic hot water
- Built in frost thermostat for flexibility of siting
- Suitable for use with the Multifit GasSaver, which can give annual gas savings on DHW of up to 37% over a SEDBUK Band A boiler.



\*Subject to registration and an annual service



'The Baxi Duo-tec Combi 28HE is CORGI Boiler of the Year 2008.'





# Duo-tec Combi HE A

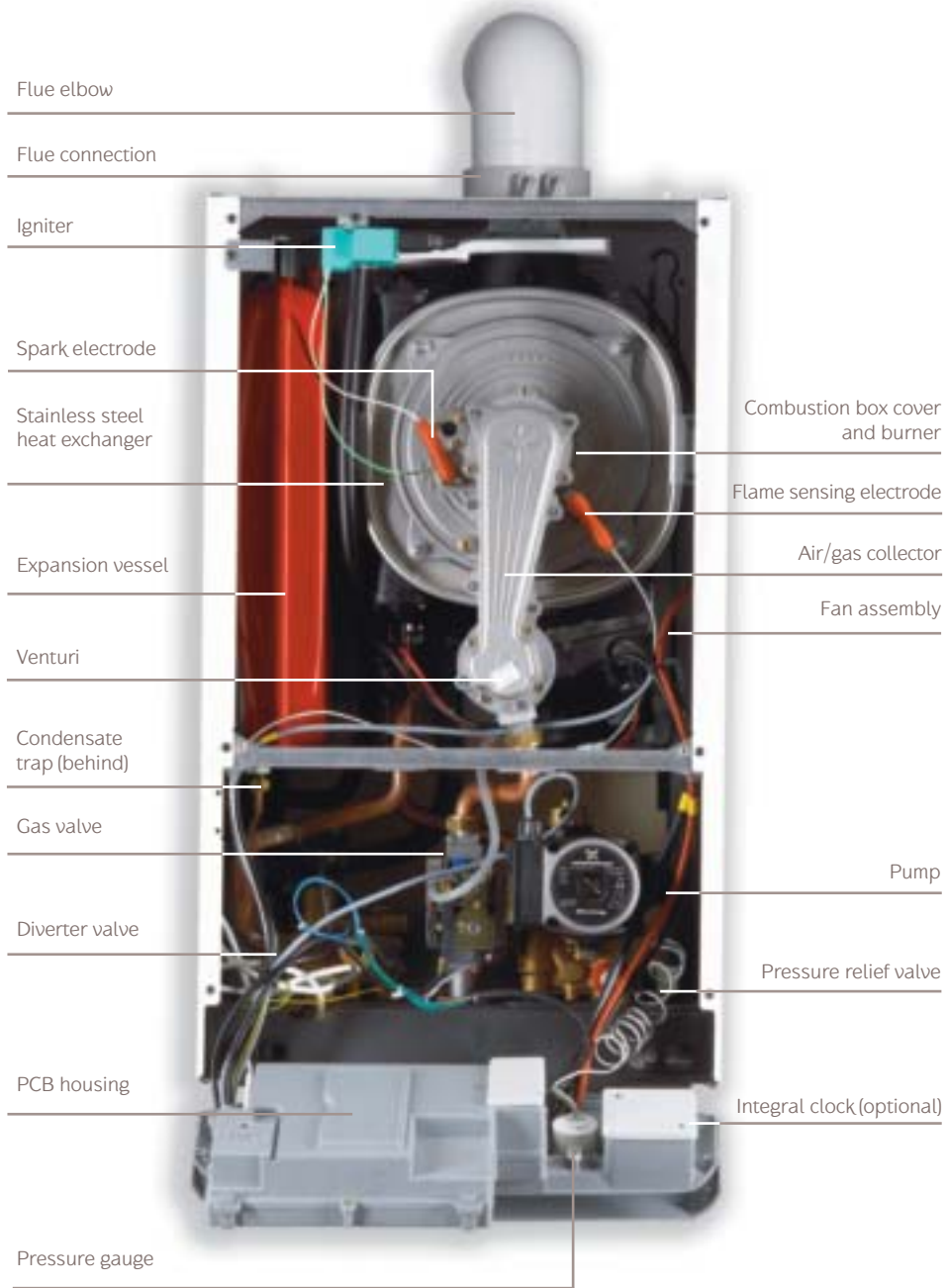

Fully modulating outputs



SEDBUK 2005 Band A (>90%)



Ultra low NO<sub>x</sub> emissions class 5 - helping to protect the environment



Can be located in unventilated cupboards or compartments



Exceptional flow rates of up to 16 l/min at 35°C temp rise



24kW, 28kW and 33kW are available as LPG models





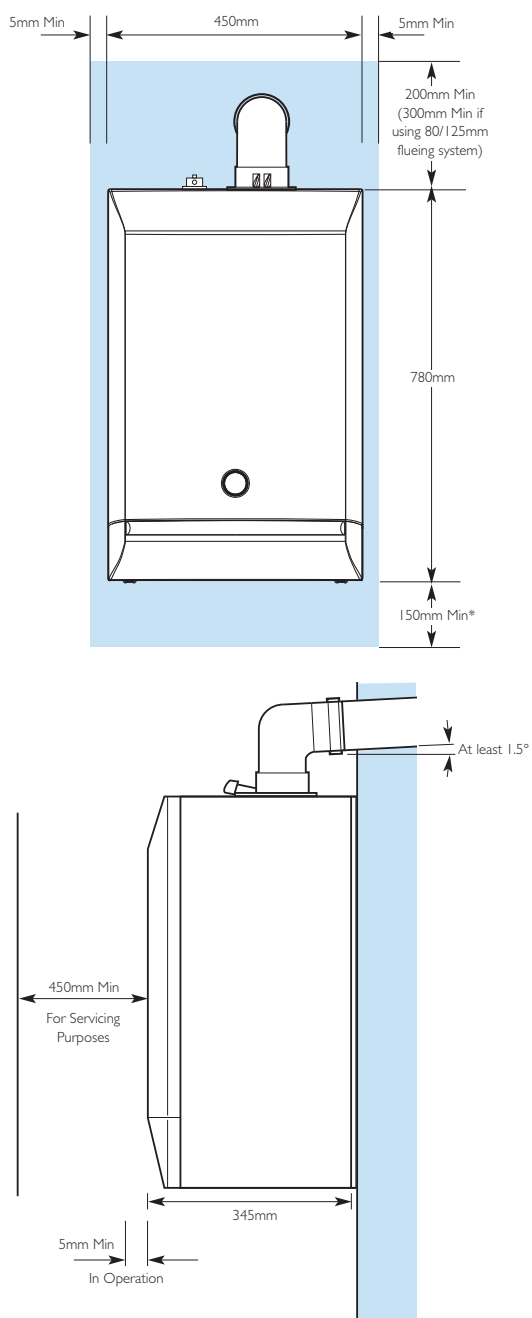

\* This is the MINIMUM recommended dimension.  
Greater clearance will aid installation and maintenance.

## Baxi Duo-tec Combi HE A Series: Wall mounted high efficiency combination boilers

		24 HE A	28 HE A	33 HE A	40 HE A
<b>CONTROLS</b>					
Concealed User Controls		Yes	Yes	Yes	Yes
On/Off Switch with Reset		Yes	Yes	Yes	Yes
User Adjustable DHW Temperature		Yes	Yes	Yes	Yes
User Adjustable CH Temperature		Yes	Yes	Yes	Yes
LED Temp/Status/Fault Diagnosis Display		2 digits/3 LEDs	2 digits/3 LEDs	2 digits/3 LEDs	2 digits/3 LEDs
<b>GAS</b>					
Gas Supply Pipe Size	mm	22	22	22	22
Natural Gas		Yes	Yes	Yes	Yes
LPG (Butane/Propane)		Yes	Yes	Yes	No
Nominal Inlet Supply Pressure NG/LPG	mbar	20 /N/A	20 /37	20 / N/A	20 / N/A
Maximum Gas Rate NG/LPG	m <sup>3</sup> /hr / kg/hr	2.61/1.92	3.10/2.32	3.59/2.64	4.36/N/A
Heat Input Central Heating	kW Max Gross	22.7	27.4	32.1	36.4
	kW Max Net	20.5	24.7	28.9	32.8
	kW Min Gross	7.8	10.0	10.8	11
	kW Min Net	7	9	9.7	9.9
Heat Output CH Non Condensing (70° Mean)	kW Max	20	24	28	32
	kW Min	6.8	8.7	9.4	9.6
Heat Output CH Condensing (40° Mean)	kW Max	21	25.9	30.3	34.4
	kW Min	7.4	9.5	10.2	12.1
Heat Input Domestic Hot Water	kW Max Gross	27.4	32.1	37.7	45.7
	kW Max Net	24.7	28.9	34	41.2
Heat Output Domestic Hot Water	kW Max	24	28	33	40
Maximum Domestic Hot Water Flow Rate	l/min @ 35°C Rise	9.8	11.5	13.5	16.4
Seasonal Efficiency NG/LPG	%	91.1/93.2	91.1/93.2	91.1/93.2	91.1/N/A
SEDBUK Rating	Band	A	A	A	A
NO <sub>x</sub> Class		5	5	5	5
NO <sub>x</sub> Levels	mg / kWhr	22.3	26.0	21.8	25.2
<b>ELECTRICAL</b>					
Electrical Supply	Volts / Hz	230V / 50Hz	230V / 50Hz	230V / 50Hz	230V / 50Hz
Permanent Live Required		Yes	Yes	Yes	Yes
Fitted Electrical Cable		1m x 3 core x 0.75mm <sup>2</sup>			
Power Consumption	Watts	155	155	160	160
External Fuse Rating	Amps	3	3	3	3
Internal Fuse Rating	Amps	F2L	F2L	F2L	F2L
Ingress Protection Rating (without electro-mechanical timer fitted)		IPX 5D	IPX 5D	IPX 5D	IPX 5D
24 hour Pump Exercise		Yes	Yes	Yes	Yes
Pump Overrun		Yes	Yes	Yes	Yes
Integral 'Boiler Only' Frost Thermostat		Yes	Yes	Yes	Yes
<b>MECHANICAL &amp; HYDRAULIC</b>					
Compartment Ventilation Requirement		None	None	None	None
Pre-plumbing/Wall Mounting Jig		Yes	Yes	Yes	Yes
Flow & Return Pipe Size	mm	22	22	22	22
Condensate Discharge Pipe Size	mm	21.5	21.5	21.5	21.5
Integral Automatic Bypass		Yes	Yes	Yes	Yes
Min Domestic Hot Water Flow Rate	l/min	2	2	2	2
Min Domestic Hot Water Operating Pressure	bar	0.15	0.15	0.15	0.15
Maximum DHW System Pressure	bar	8	8	8	8
Safety Discharge Pressure	bar	3	3	3	3
Integral Expansion Vessel Capacity	litres	8	8	10	10
Max Capacity of Central-Heating System	litres	125	125	155	155
Filling Loop included		Yes	Yes	Yes	Yes
CH System Inhibitor Required		Hard Water only			
<b>CONCENTRIC FLUE SYSTEM</b>					
Standard Telescopic Horizontal Flue Kit Length	mm	315 - 500			
Max Equiv Length Horizontal/Vertical (60/100mm)	m	10	10	10	10
Max Equiv Length Horizontal/Vertical (80/125mm)	m	20	20	20	20
Equivalent Length per 135° Bend	m	0.5	0.5	0.5	0.5
Equivalent Length per 93° Bend	m	1	1	1	1
<b>TWIN PIPE FLUE SYSTEM</b>					
Diameters	mm	80 / 80	80 / 80	80 / 80	80 / 80
Max Equiv Length Horizontal/Vertical (parallel pipes)	m	15/15	15/15	15/15	15/15
Equivalent Length per 135° Bend	m	0.25	0.25	0.25	0.25
Equivalent Length per 91.5° Bend	m	0.5	0.5	0.5	0.5
<b>WEIGHTS</b>					
Max Installation Lift Weight	kg	43.6	44.2	46	46
Gross Packaged Boiler Weight	kg	48.6	49.2	51	51



Baxi Solo HE A boilers have always been popular with both installers and homeowners alike.

The simple contemporary lines and soft curves are bound to appeal to customers, as will the beautifully simple controls that make it easy to use. It's clean, compact design makes it perfect where space is limited.

It may be small in size, but it's big in performance, with an extended range of models now available, making it the perfect heating only choice for any size property.

## Key features & benefits:

- 2-year parts and labour warranty\* giving customers complete peace of mind through our **heateam**

- SEDBUK 2005 Band A (>90%) rated
- Available in five outputs 12kW, 15kW, 18kW, 24kW and 30kW, this modulating boiler fits most size systems
- Lightweight, compact design for flexible siting
- Can be installed on a fully TRV system
- Suitable for use with open vented or sealed heating systems
- Simple controls for easy operation
- No pump overrun required, meaning this boiler will directly replace any existing heat only boiler



\*Subject to registration and an annual service



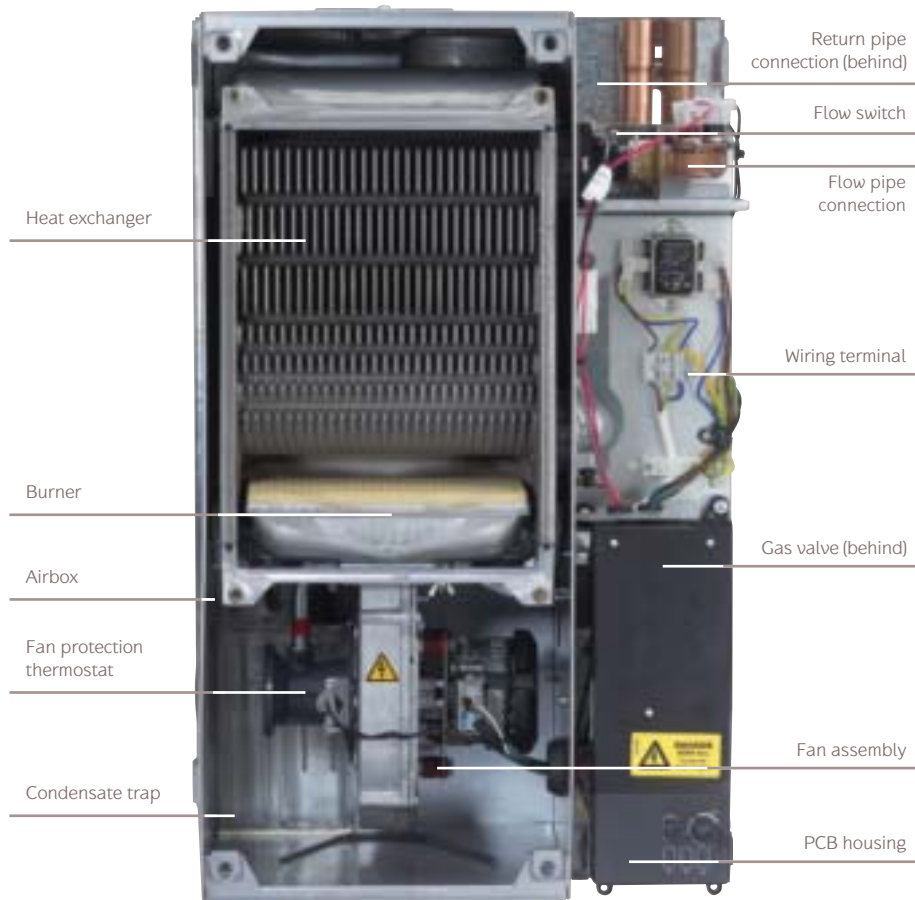

## Megaflo HE SystemFit

The Baxi Solo HE A is compatible with the Heatrae Sadia Megaflo HE SystemFit cylinder

- Available in 125-300 litre capacities
- Supplied with primary expansion vessel, programmable thermostat and room sensor
- Up to 70% quicker to install
- Lifetime on-site parts and labour cylinder guarantee, 5 year guarantee on cold water controls and primary expansion vessel and 2 year guarantee on all other parts

For further details on the Megaflo range, please call 01603 420220 or visit [www.heatraesadia.com](http://www.heatraesadia.com)



Fully modulating outputs



SEDBUK 2005 Band A (>90%)



Ultra low NO<sub>x</sub> emissions class 5 - helping to protect the environment



Can be located in unventilated cupboards or compartments



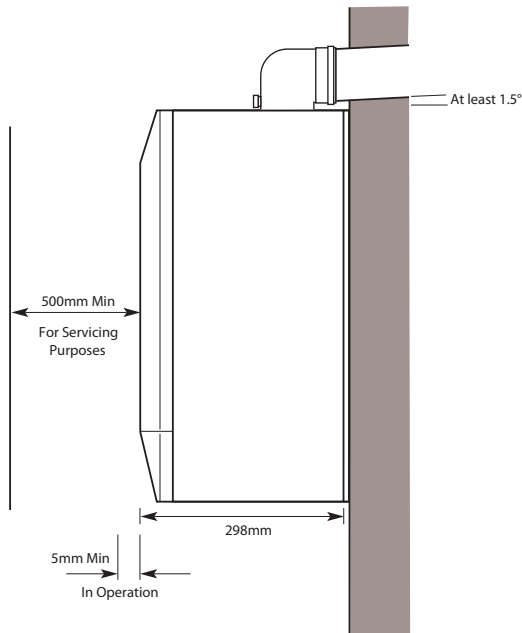
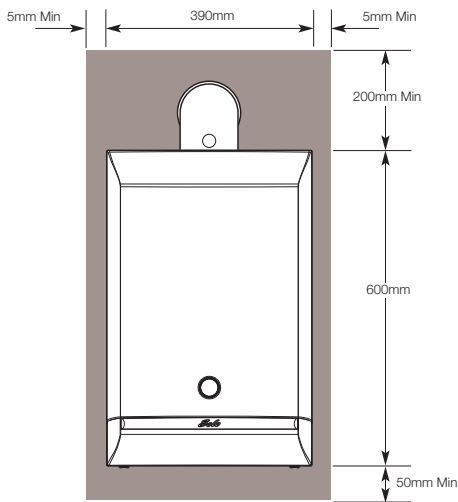

## Baxi Solo HE A Series: Wall mounted high efficiency boilers

		12 HE A	15 HE A	18 HE A	24 HE A	30 HE A
<b>CONTROLS</b>						
Concealed User Controls		Yes	Yes	Yes	Yes	Yes
User Adjustable CH Temperature		Yes	Yes	Yes	Yes	Yes
LED Status/Fault Diagnosis Display		Yes	Yes	Yes	Yes	Yes
<b>GAS</b>						
Gas Supply Pipe Size	mm	15	15	15	15	15
Natural Gas		Yes	Yes	Yes	Yes	Yes
LPG (Butane/Propane)		No	No	No	No	No
Nominal Inlet Supply Pressure	mbar	20	20	20	20	20
Maximum Gas Rate	m <sup>3</sup> /hr	1.34	1.64	1.94	2.51	2.95
Heat Input Central Heating	kW Max Gross	13.3	16.9	20.2	24.5	33.8
	kW Max Net	12.0	15.2	18.2	22.1	30.4
Heat Output CH Non Condensing	kW Max	11.8	15.2	17.8	22	30.2
Heat Output CH Condensing	kW Max	12.8	16.5	19.3	23.8	32.6
Seasonal Efficiency	%	90.5	91.3	90.4	90.9	90.9
SEDBUK Rating	Band	A	A	A	A	A
NO <sub>x</sub> Class		5	5	5	5	5
NO <sub>x</sub> Levels	mg / kWh	13.1	29.0	11.7	37.0	48.0
<b>ELECTRICAL</b>						
Electrical Supply	Volts / Hz	230V / 50Hz	230V / 50Hz	230V / 50Hz	230V / 50Hz	230V / 50Hz
Permanent Live Required		No	No	No	No	No
Electrical Cable Required		3 core x 0.75mm <sup>2</sup>				
Power Consumption	Watts	80	80	80	80	80
External Fuse Rating	Amps	3	3	3	3	3
Internal Fuse Rating	Amps	3.15	3.15	3.15	3.15	3.15
Ingress Protection Rating (without electro-mechanical timer fitted)		IPX2	IPX2	IPX2	IPX2	IPX2
Integral 'Boiler Only' Frost Thermostat		No	No	No	No	No
Pump Overrun		No	No	No	No	No
<b>MECHANICAL &amp; HYDRAULIC</b>						
Compartment Ventilation Required		None	None	None	None	None
Flow & Return Pipe Size	mm	22	22	22	22	22
Condensate Discharge Pipe Connection	mm	21.5	21.5	21.5	21.5	21.5
Bypass Required		No	No	No	No	No
Vertical Pipe Route		Within Case				
CH System Inhibitor Required		Yes	Yes	Yes	Yes	Yes
<b>CONCENTRIC FLUE SYSTEM</b>						
Outside Diameter	mm	110	110	110	110	110
Standard Horizontal Flue Kit Length	mm	850	850	850	850	850
Max Equivalent Length Horizontal	m	4 plus Terminal				
Max Equivalent Length Vertical	m	4 plus Terminal				
Equivalent Length per 135° Bend	m	0.5	0.5	0.5	0.5	0.5
Equivalent Length per 93° Bend	m	1	1	1	1	1
<b>TWIN PIPE FLUE SYSTEM</b>						
Diameters	mm	80/80	80/80	80/80	80/80	80/80
Max Equivalent Length Horizontal (parallel pipes)	m	75	75	75	75	75
Max Equivalent Length Vertical (parallel pipes)	m	75	75	75	75	75
Equivalent Length per 135° Bend	m	1.3 Air & 2.6 Flue				
Equivalent Length per 90° Bend	m	4.8 Air & 9.6 Flue				
<b>WEIGHTS</b>						
Max Installer Lift Weight	kg	26	26	26	26	26
Gross Packaged Boiler Weight	kg	36.2	36.2	36.2	36.2	36.2



The Baxi Megafluo System HE A is designed for fully pumped sealed systems - and because it's fully modulating, it's the perfect choice for a wide range of applications.

The Baxi Megafluo System HE A also works with central heating and indirect hot water systems.

It's ideal for fitting in unventilated cupboards, and comes with a wall mounting frame and integral isolating valves for easy pre-plumbing and flushing of the system prior to fitting.

## Key features & benefits:

- 2-year parts and labour warranty\* giving customers complete peace of mind through our **heateam**

- SEDBUK 2005 Band A (>90%) rated
- Available in five outputs; 15kW, 18kW, 24kW, 28kW and 32kW, this modulating boiler fits most size systems. The 18kW, 28kW and 32kW are also available as LPG models
- Supplied with pre-plumbing jig for easier and labour saving installation
- Integral automatic bypass, suitable for systems incorporating TRVs to every radiator
- Comprehensive range of flue options for quick installation
- Built in frost thermostat for flexible siting



\*Subject to registration and an annual service



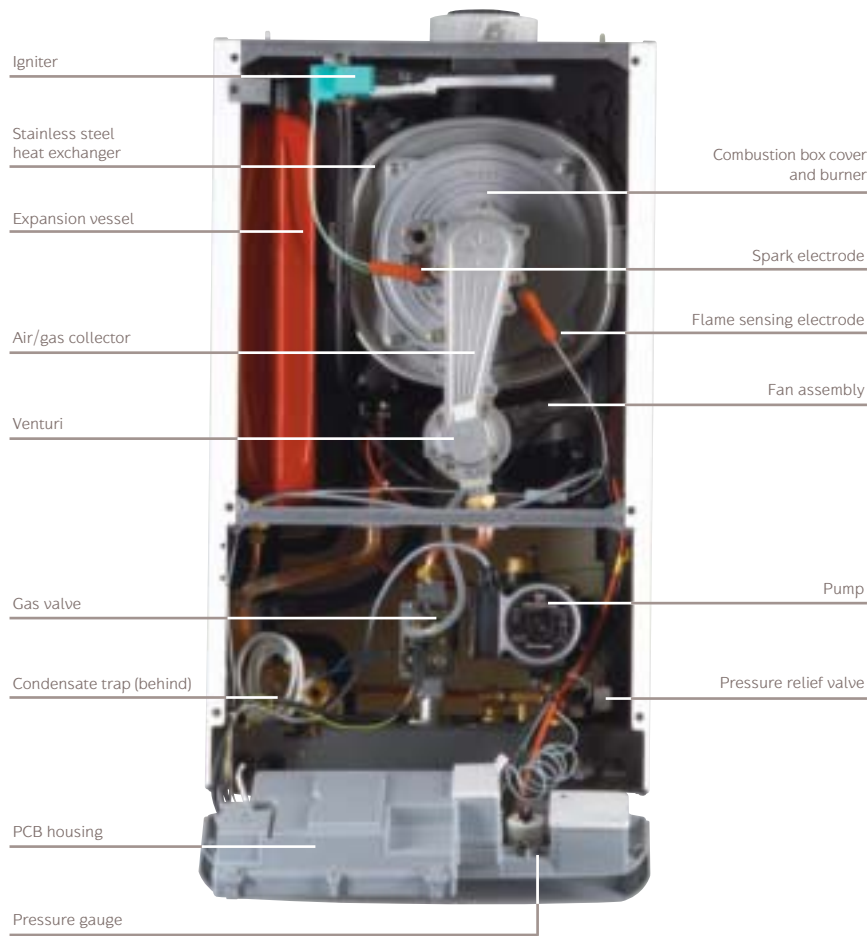

## Megaflor HE Unvented Cylinder

The Baxi Megaflor System HE A is compatible with the Heatrae Sadia Megaflor HE unvented cylinder

- Available in 70-300 litre options in both direct and indirect models
- Patented internal floating baffle system to accommodate hot water expansion
- High performance 'coil in coil' heat exchanger
- Lifetime year on-site parts and labour cylinder guarantee, 5 year guarantee on cold water controls and 2 year guarantee on all other parts

For further details on the Megaflor range, please call 01603 420220 or visit [www.heatraesadia.com](http://www.heatraesadia.com)



Fully modulating outputs



SEDBUK 2005 Band A (>90%)



Ultra low NO<sub>x</sub> emissions class 5 - helping to protect the environment



Can be located in unventilated cupboards or compartments



18kW, 28kW and 32kW are available as LPG models



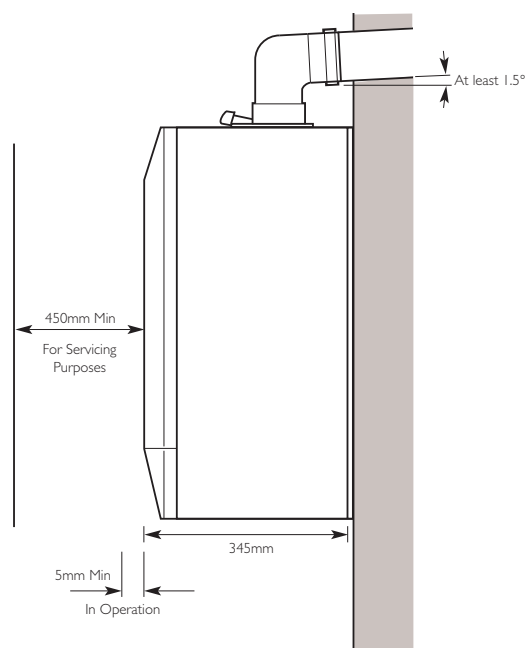
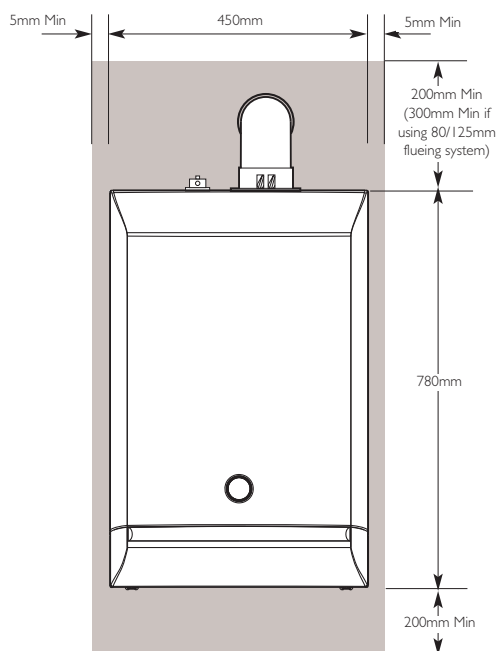

## Baxi Megafluo System HE A: Wall mounted high efficiency boilers

15 HE A 18 HE A 24 HE A 28 HE A 32 HE A

CONTROLS		15 HE A	18 HE A	24 HE A	28 HE A	32 HE A
Concealed User Controls		Yes	Yes	Yes	Yes	Yes
On/Off Switch with Reset		Yes	Yes	Yes	Yes	Yes
User Adjustable CH Temperature		Yes	Yes	Yes	Yes	Yes
LED Temp/Status/Fault Diagnosis Display	2 digits & 3 LEDs					
GAS						
Gas Supply Pipe Size	mm	22	22	22	22	22
Natural Gas		Yes	Yes	Yes	Yes	Yes
LPG (Butane/Propane)		No	Yes	No	Yes	Yes
Nominal Inlet Supply Pressure	mbar	20	20	20	20	20
Max Gas Rate NG/LPG	m <sup>3</sup> /hr / kg/hr	1.69/N/A	1.95/1.44	2.61/N/A	3.10/2.25	3.48/2.49
Heat Input Central Heating	kW Max Gross	17.1	20.5	27.4	32.1	36.4
	kW Max Net	15.4	18.5	24.7	28.9	32.8
	kW Min Gross	4.4	4.8	7.8	10.8	10.8
	kW Min Net	4.0	4.3	7	9.7	9.7
Heat Output CH Non Condensing (70° Mean)	kW Max	15	18	24	28	32
	kW Min	3.9	4.2	6.8	9.4	9.4
Heat Output CH Condensing (40° Mean)	kW Max	16.2	19.4	25.9	30.3	34.4
	kW Min	4.2	4.5	7.4	10.2	10.2
Seasonal Efficiency NG/LPG	%	91.2/N/A	91.2/93.2	91.2/N/A	91.2/93.2	91.2/93.2
SEDBUK Rating	Band	A	A	A	A	A
NO <sub>x</sub> Class		5	5	5	5	5
NO <sub>x</sub> Levels	mg / kWhr	27.5	31.7	22.3	21.8	26.8
ELECTRICAL						
Electrical Supply	Volts / Hz	230V / 50Hz				
Permanent Live Required		Yes	Yes	Yes	Yes	Yes
Fitted Electrical Cable		1 m x 3 core x 0.75mm <sup>2</sup>				
Power Consumption	Watts	130	140	150	160	160
External Fuse Rating	Amps	3	3	3	3	3
Internal Fuse Rating	Amps	F2L	F2L	F2L	F2L	F2L
Ingress Protection Rating (without electro-mechanical timer fitted)		IPX5D	IPX5D	IPX5D	IPX5D	IPX5D
24 hour Pump Exercise		Yes	Yes	Yes	Yes	Yes
Pump Overrun		Yes	Yes	Yes	Yes	Yes
Integral 'Boiler Only' Frost Thermostat		Yes	Yes	Yes	Yes	Yes
MECHANICAL & HYDRAULIC						
Compartment Ventilation Requirement		None	None	None	None	None
Pre-plumbing/Wall Mounting Jig		Yes	Yes	Yes	Yes	Yes
Flow / Return Pipe Size	mm	22	22	22	22	22
Condensate Discharge Pipe Size	mm	21.5	21.5	21.5	21.5	21.5
Integral Automatic Bypass		Yes	Yes	Yes	Yes	Yes
Safety Discharge Pressure	bar	3	3	3	3	3
Integral Expansion Vessel	litres	8	8	8	10	10
Maximum Capacity of CH System	litres	125	125	125	125	125
CH System Inhibitor Required		Yes	Yes	Yes	Yes	Yes
CONCENTRIC FLUE SYSTEM						
Standard Telescopic Horizontal Flue Kit Length	mm	315 - 500	315 - 500	315 - 500	315 - 500	315 - 500
Max Equivalent Length Horizontal/Vertical (60/100mm)	m	10	10	10	10	10
Max Equivalent Length Vertical Horizontal/Vertical (80/125mm)	m	20	20	20	20	20
Equivalent Length per 135° Bend	m	0.5	0.5	0.5	0.5	0.5
Equivalent Length per 93° Bend	m	1	1	1	1	1
TWIN PIPE FLUE SYSTEM						
Diameters	mm	80 / 80	80 / 80	80 / 80	80 / 80	80 / 80
Max Equivalent Length Horizontal/Vertical (parallel pipes)	m	15/15	15/15	15/15	15/15	15/15
Equivalent Length per 135° Bend	m	0.25	0.25	0.25	0.25	0.25
Equivalent Length per 91.5° Bend	m	0.5	0.5	0.5	0.5	0.5
WEIGHTS						
Max Installation Lift Weight	kg	38.6	38.6	39.2	41	41
Gross Packaged Boiler Weight	kg	43.6	43.6	44.2	46	46



The original Baxi Bermuda Back Boiler Unit (BBU), launched in 1966, was so practical and reliable that Baxi installations accounted for 80% of the back boilers installed in the UK.

Times changed and so did boilers, but with the introduction of our innovative new Baxi Bermuda BBU HE we continue our tradition of back boiler expertise. As the only high efficiency BBU in the UK, it's the easiest way to replace an existing BBU.

The Baxi Bermuda BBU HE has been specifically designed to work with the Valor Dimension™ range of BBU Firefronts.

## Key features & benefits - Baxi Bermuda BBU HE

- 2-year parts and labour warranty\* giving customers complete peace of mind through our **heateam**
- SEDBUK 2005 Band A (>90%) rated
- 15kW heat output; modulating boiler adapts to heat demand ensuring optimum performance at all times

- Built in condensate pump and no pump overrun required, to ease installation
- Factory set to enable easy boiler commissioning
- Single piece flexible concentric flue; eliminates the need to provide flue inspection access
- Room sealed appliance; eliminating the need for air vents in the room
- Simple to use external boiler controls located on the dedicated Valor Dimension™ firefront
- Quiet in operation

## Key features & benefits - Valor Dimension™

- 2-year parts and labour warranty\* giving customers complete peace of mind through **heateam**
- Traditional and contemporary fire front designs
- Running costs for the fire using the 'effect', are less than 2p per day
- Heat outputs of 1kW and 2kW
- No servicing required
- The BBU Firefront range is a unique range dedicated to the Baxi Bermuda Back Boiler Unit package

\*Subject to registration and an annual service



Gas Industry  
Innovation Award 2010

**A** >90%





The 3D diagram below displays the key components of the Baxi Bermuda BBU HE.

- |  |                                 |
|--|---------------------------------|
| 1. Automatic Air Vent                              | 11. Fan                         |
| 2. Flue Connection                                 | 12. Drain                       |
| 3. Spark Generator (located behind PCB)            | 13. Return Connection           |
| 4. Spark & Sensing Electrodes (located behind PCB) | 14. Air Sampling Point          |
| 5. Heat Exchanger (located behind PCB)             | 15. Flue Sampling Point         |
| 6. User Interface Connector                        | 16. Flow Connection             |
| 7. Control Wiring Connector                        | 17. Condensate Outlet           |
| 8. Condensate Sump                                 | 18. PCB Control Box             |
| 9. Gas Cock  | 19. Boiler Control (cover open) |
| 10. Condensate Pump                                |                                 |





Baxi Bermuda BBU HE		
<b>CONTROLS</b>		
Concealed User Controls		Yes
User Adjustable CH Temperature		Factory Preset
LED Status/Fault Diagnosis Display		Yes
<b>GAS</b>		
Gas Supply Pipe Size	mm	15mm compression
Natural Gas		Yes
LPG (Butane/Propane)		No
Nominal Inlet Supply Pressure	m <sup>3</sup> /hr	20
Maximum Gas Rate		1.63
Heat Input Central Heating	kW Max Gross kW Max Net	17.1 15.38
Heat Output CH Non Condensing	kW Max	15
Heat Output CH Condensing	kW Max	15.7
Seasonal Efficiency	%	90.1
SEDBUK Rating	Band	A
Nox Class		5
Nox Levels	mg/kWh	31
<b>ELECTRICAL</b>		
Electrical Supply	Volts/Hz	230/50Hz
Permanent Live Required		Yes
Electrical Cable Required		4 core wire
Power Consumption	Watts	112
External Fuse Rating	Amps	3
Internal Fuse Rating	Amps	3.15
Ingress Protection Rating		IPX0
Pump Overrun		not required
<b>MECHANICAL &amp; HYDRAULIC</b>		
Compartment Ventilation Required		No
Flow & Return Pipe Size	mm	22 male copper
Condensate Discharge Pipe Connection	mm	10
Bypass Required		Yes (pressure operated)
Vertical Pipe Route		no inverted pipework permitted
CH System Inhibitor Required		Yes
<b>CONCENTRIC FLUE SYSTEM</b>		
Outside Diameter	mm	100
Max Equivalent Length Vertical	m	10 or 12.5
<b>WEIGHTS</b>		
Max Installer Lift Weight	kg	27
Gross Packaged Boiler Weight	kg	28
<b>ACCESSORIES</b>		
Right Hand Plumb Kit	Sales Code	720111701

## Boiler dimensions

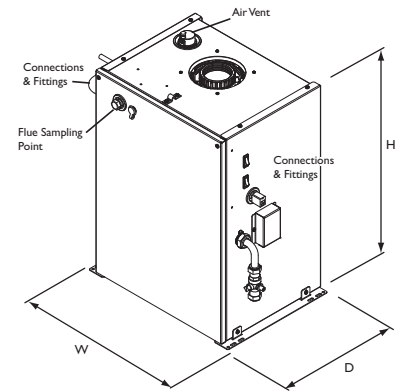

W (Width) = 430mm including connections & fittings  
 D (Depth) = 330mm including flue sampling point  
 H (Height) = 550mm including air vent

## Site requirements†

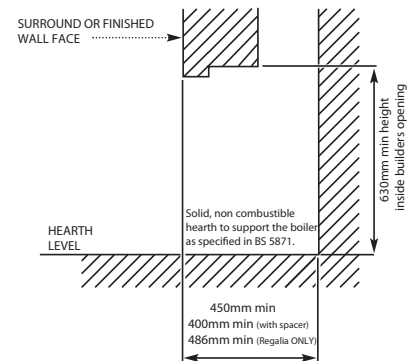
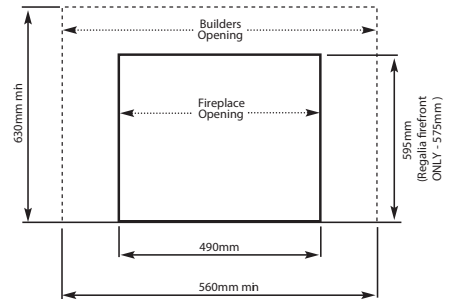

## Site requirements†

- 1 To accommodate the firefront without the need for additional spacers, there must be a gap of at least 94mm from the surround or finished face to the front of the boiler.
- 2 If necessary this gap can be increased by the use of spacer kits . Each spacer increases the effective depth of the opening by up to 50mm. Alternatively a range of rebated fire surrounds are available.
- 3 When surveys highlight that space is restricted versus minimum site requirements, the use of rebated surrounds is recommended.

# Valor Fire, Surround, Back Panel and Hearth Technical Specification

FIRES	All measurements given in mm						
Model	Fire only	Boiler & Fire	Fascia Height	Fascia Width	Fascia Depth	Engine Depth	Spacer Depth
Valor Dimension™ Regalia BBU Firefront †	05847A1	720331401	720	600	45	144	50
Valor Dimension™ Innova BBU Firefront ★	0584711	720331301	632	542	38	144	50
Valor Dimension™ Classica Brass BBU Firefront †	0584721	720330701	615	512	51	144	50
Valor Dimension™ Classica Pewter BBU Firefront †	0584701	720330801	615	512	51	144	50
Valor Dimension™ Classica Black BBU Firefront †	05847B1	720330901	615	512	51	144	50
Valor Dimension™ Dream Gold BBU Firefront †	05847C1	720331001	636	518	79	144	50
Valor Dimension™ Dream Chrome BBU Firefront †	05847D1	720331101	636	518	79	144	50
Valor Dimension™ Dream Black BBU Firefront †	05847E1	720331201	636	518	79	144	50
Valor Dimension™ Lyrica BBU Firefront †	0584511	720331601	612	510	74	144	50
Valor Dimension™ Nano Chrome BBU Firefront †	0584521	720331501	616	512	49	144	50

SURROUNDS* AND ACCESSORIES	All measurements given in mm				
Model	Part Number	Height	Width	Depth	Rebate
Calista Oak 6" Rebate Surround	05070P3	1084	1230	220	150
Barcelona Black 6" Rebate Solo-pro Surround	0507052	1032	1170	200	150
Calista Oak Surround	05070B1	1084	1230	190	75/25
Calista Mahogany Surround	05070C1	1084	1230	190	75/25
Clarissa Oak Surround	05070A1	1097	1230	190	75/25
Barcelona Black Surround	05070M2	1032	1170	150	25
Olympia Cream Surround	05070G2	1055	1180	170	25
Teviot White Surround Set	05070W3	1100	1200	380	75
Teviot Maple Surround Set	05070X2	1100	1200	380	75
Medway Oak Surround Set	05070X3	1100	1200	380	75
Medway Mahogany Surround Set	05070Y2	1100	1200	380	75
Solo-Pro 48" Hearth with Back Panel Black	0507011	990	1220	375	NA
Solo-Pro 48" Hearth with Back Panel Cream	0507001	990	1220	375	NA
Solo-Pro 48" Hearth with Back Panel White	0507012	990	1220	375	NA
Classica, Lyrica, Nano & Innova Spacer Kit	5135632	610	503	50	NA
Regalia Spacer Kit	5135633	715	586	50	NA
Dream Spacer Kit	5135634	625	504	50	NA
Right Hand Plumb Kit	720111701	NA	NA	NA	NA
BBU Wall Fascia ^	05847H1	750	650	157	NA
10m Concentric Flexible flue	710143901	OD Dimension 100mm (complete with terminal)			
12.5m Concentric Flexible flue	710144001	OD Dimension 100mm (complete with terminal)			
Flue Pull Cone #	720111801	OD Dimension 100mm (complete with terminal)			

\*Please note that a fire surround (new or existing) is required to complete the installation in order to conceal the builders opening.

† This fire is floor standing only.

★ This fire can be wall mounted or floor standing.

^ For use with the Innova fire surround.

# The flue pull cone must be used for pulling the concentric flexible flue down the chimney. The flue pull cone can then be retained for future installations.



# Flue Options

## Flue Options

- Baxi Boilers can be fitted with flue systems as illustrated.
- The standard flue is suitable only for horizontal termination applications.
- Maximum permissible equivalent flue lengths for Platinum Combi HE A, Duo-tec Combi HE A, Megafluo HE A are:
 

	Group A	Group G
Horizontal Concentric	10 metres	20 metres
Vertical Concentric	10 metres	20 metres
Horizontal Twin pipe	15 metres	
Vertical Twin Pipe	15 metres	

Maximum permissible equivalent flue lengths for Solo HE A are:

Horizontal Concentric	4 metres
Vertical Concentric	4 metres
Horizontal Twin pipe	75 metres (parallel pipes)
Vertical Twin Pipe	75 metres (parallel pipes)

- Any additional "in line" bends in the flue system must be taken into consideration. Their equivalent lengths for Platinum Combi HE A, Duo-tec Combi HE A, Megafluo HE A are:

	Group A	Group G
Concentric Pipes	135° bend	0.5 metres
	93° bend	1 metre

The elbow supplied with the standard horizontal telescopic flue kit is not included in any equivalent length calculations for Platinum Combi HE A, Duo-tec Combi HE A, Megafluo HE A are:

	Group A	Group G
Twin Flue Pipe	135° bend	0.25 metres
	91.5° bend	0.50 metres







The elbow supplied with the standard horizontal telescopic flue kit is not included in any equivalent length calculations for Solo HE A are:

Twin Flue Pipe	135° bend (air duct)	1.3 m
	135° bend (flue duct)	2.6 m
	91.5° bend (air duct)	4.8 m
	91.5° bend (flue duct)	9.6 m

The elbow supplied with the boiler is not included in any equivalent length calculations.

- The illustrations show examples of permissible flue systems.
- Instructions for guidance and fitting are included in each kit, where appropriate.





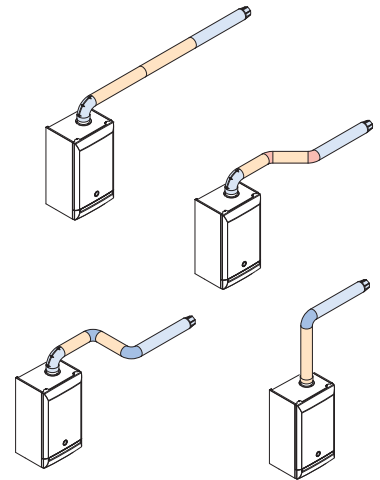

### GROUP A Concentric Horizontal Flue System 60/100mm diameter for use with Platinum Combi HE A, Duo-tec Combi HE A and Megafluo HE A

Key	Item Description	Specification	OD Dimensions	Multifit Sales Code
	Standard Horizontal Telescopic Flue inc Elbow	315mm - 500mm	60/100mm	5118069
	Standard Horizontal Flue inc Elbow	685mm	60/100mm	5118489
Not illustrated	Telescopic Internal Flue Kit		100mm	5119654
	Flue Extension	1000mm	100mm	5111074
	Flue Bend	93 degree	100mm	5111075
	Flue Bend (Pair)	135 degree	100mm	5111085
	Flue Bend	135 degree	100mm	5111076
Not illustrated	Flue Internal Fixing Kit / Wall Liner		100mm	5111067
Not illustrated	Pipe Support	Painted white	100mm	5111080
Not illustrated	Flue Terminal Deflector		60mm	5111068
Not illustrated	Low Profile Flue Elbow	93 degree	100mm	720550801

NOTE: The 3 degree fall back on concentric flues can be reduced to 1.5 degree providing the flue system is adequately clamped in accordance with the installation instructions.







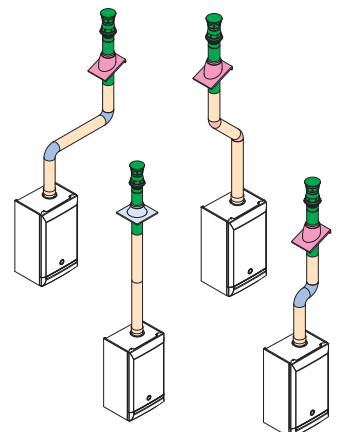



### GROUP A Concentric Vertical Flue System 60/100mm diameter for use with Platinum Combi HE A, Duo-tec Combi HE A and Megafluo HE A

Key	Item Description	Specification	OD Dimensions	Multifit Sales Code
	Vertical Flue Terminal		100mm	5118576
	Flue Extension	1000mm	100mm	5111074
	Flue Bend (Pair)	135 degree	100mm	5111085
	Flue Bend	93 degree	100mm	5111075
Not illustrated	Pipe Support	Painted White	100mm	5111080
	Pitched Roof Flashing	25/50 degree	125mm	5122151
	Flat Roof Flashing		125mm	246144
Not illustrated	Roof Cover Plate		125mm	246143



# Flue Options







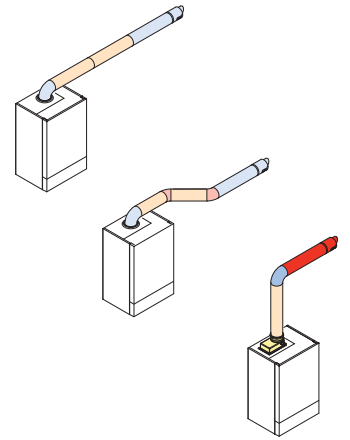

## GROUP B Concentric Horizontal Flue System 70/110mm diameter for use with Solo HE A

Key	Item Description	Specification	OD Dimensions	Multifit Sales Code
	Standard Horizontal Flue inc Elbow	850mm	110mm	236921
	Horizontal Flue / Wall Terminal	850mm	110mm	243013BAX
	Vertical Flue Adaptor (Boiler)		110mm	5106888
	Flue Extension	1000mm	110mm	241695
	Flue Extension	500mm	110mm	241694
	Flue Extension	250m	110mm	241692
	Flue Bend	93 degree	110mm	241687
	Flue Bend (Pair)	135 degree	110mm	241689
Not illustrated	Pipe Support		110mm	243014BAX
Not illustrated	Flue Terminal Deflector			248167

NOTE: The 3 degree fall back on concentric flues can be reduced to 1.5 degree providing the flue system is adequately clamped in accordance with the installation instructions.





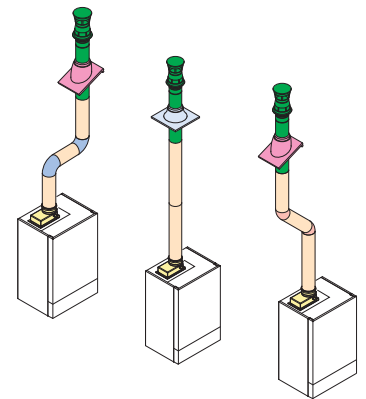

## GROUP B Concentric Vertical Flue System 70/110mm diameter for use with Solo HE A

Key	Item Description	Specification	OD Dimensions	Multifit Sales Code
	Vertical Roof Terminal		70/110mm	242802
	Vertical Flue Adaptor (Boiler)		110mm	5106888
	Flue Extension	1000mm	110mm	241695
	Flue Extension	500mm	110mm	241694
	Flue Extension	250m	110mm	241692
	Flue Bend	93 degree	110mm	241687
	Flue Bend (Pair)	135 degree	110mm	241689
Not illustrated	Pipe Support		110mm	243014BAX
	Pitched Roof Flashing	25/50 degree	125mm	243015
	Flat Roof Flashing		125mm	243016BAX
Not illustrated	Roof Cover Plate			243131



## GROUP G

Concentric Horizontal Flue System 80/125mm diameter for use with Platinum Combi HE A, Duo-tec Combi HE A and Megafluo HE A



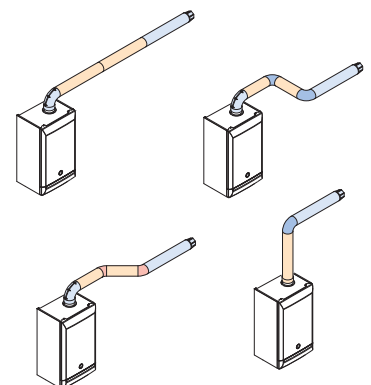



Key	Item Description	Specification	OD Dimensions	Multifit Sales Code
	Horizontal Flue inc Boiler & Terminal Adaptor		125mm	5118580
	Flue Extension	1000mm	125mm	5118584
	Flue Bend	91.5 degree	125mm	5118588
	Flue Bend (Pair)	135 degree	125mm	5118597
Not illustrated	Pipe Support	Painted white	125mm	5118610



# Flue Options

## GROUP G



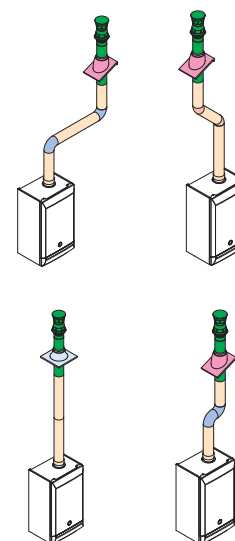

Concentric Vertical Flue System 80/125mm diameter for use with Platinum Combi HE A, Duo-tec Combi HE A and Megafluo HE A

Key	Item Description	Specification	OD Dimensions	Multifit Sales Code
	Vertical Flue Terminal		125mm	5111078
Not illustrated	Flue Vertical Adaptor		100/125mm	5111070
	Flue Extension	1000mm	125mm	5118584
	Flue Bend	91.5 degree	125mm	5118588
	Flue Bend (Pair)	135 degree	125mm	5118597
Not illustrated	Pipe Support		125mm	5118610
	Pitched Roof Flashing	25/50 degree	125mm	5122151
	Flat Roof Flashing		125mm	246144
Not illustrated	Roof Cover Plate		125mm	246143





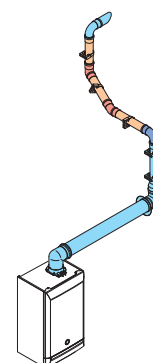

## GROUP K

Plume Displacement Kits 60/100mm diameter for use with Platinum Combi HE A, Duo-tec Combi HE A and Megafluo HE A

Key	Item Description	Specification	OD Dimensions	Multifit Sales Code
	Plume Displacement Kit inc Elbow & Clips		100mm	5118638
	Plume Displacement Kit Extension inc Clip	1000mm	60mm	5121368
	Plume Displacement Kit Bend	93 degree	60mm	5121369
	Plume Displacement Kit Bend (Pair)	135 degree	60mm	5121370



## GROUP L Plume Displacement Kits 70/110mm diameter for use with Solo HE A

Key	Item Description	Specification	OD Dimensions	Multifit Sales Code
	Plume Displacement Kit inc Elbow & Clips		110mm	5121371
	Plume Displacement Kit Extension & Clip	1000mm	70mm	5121372
	Plume Displacement Kit Bend	93 degree	70mm	5121373
	Plume Displacement Kit Bend (Pair)	135 degree	70mm	5121374

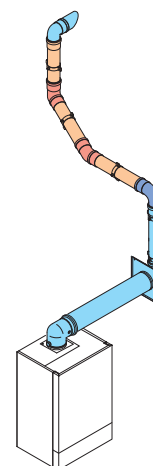

# Flue Options

## GROUP N

Twin Flue System 80/80mm diameter for use with Platinum Combi HE A, Duo-tec Combi HE A and Megaflo HE A

Key	Item Description	Specification	OD Dimensions	Multifit Sales Code
	Twin Pipe Flue Horizontal Terminal Kit		80mm	5120172
	Vertical Flue Terminal		125mm	5111078
	Twin to Concentric Adaptor 80/80 - 80/125		80/125mm	5111084
	Twin Pipe Flue Adaptor (Boiler)		80/80mm	720089801
	Twin Pipe Extension (Pair inc Brackets)	1000mm	80mm	5111087
	Twin Pipe Flue Bend (Pair)	90 degree	80mm	5111072
	Twin Pipe Flue Bend (Pair)	135 degree	80mm	5111086
Not illustrated	Twin Pipe Support (Pair)	Painted white	80mm	5111081
	Pitched Roof Flashing	25/50 degree	125mm	5122151
Not illustrated	Flat Roof Flashing		125mm	246144
Not illustrated	Roof Cover Plate		100mm	246143

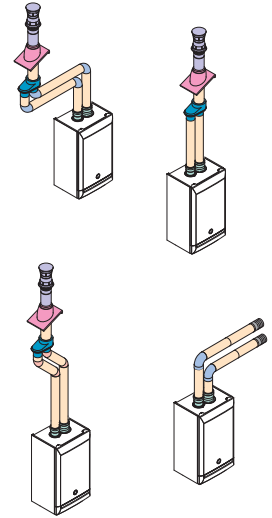

## GROUP P Twin Flue System 80/80mm diameter for use with Solo HE A

Key	Item Description	Specification	OD Dimensions	Multifit Sales Code
	Vertical Roof Terminal		70/110mm	242802
	Horizontal / Wall Terminal	850mm	110mm	243013BAX
	Twin Pipe Flue Adaptor Set			242757
	Twin Pipe Flue Extension	250mm	80mm	246135
	Twin Pipe Flue Extension	500mm	80mm	246136
	Twin Pipe Flue Extension	1000mm	80mm	246137
	Twin Pipe Flue Bend (Pair)	90 degree	80mm	5121560
Not illustrated	Twin Pipe Flue Bend (Pair)	135 degree	80mm	5121561
Not illustrated	Pipe Support		110mm	243014BAX
Not illustrated	Twin Pipe Support (Pair)		80mm	5111081
	Pitched Roof Flashing	25/50 degree	125mm	243015
Not illustrated	Flat Roof Flashing			243016BAX
Not illustrated	Flue Terminal Deflector			248167
Not illustrated	Roof Cover Plate			243131

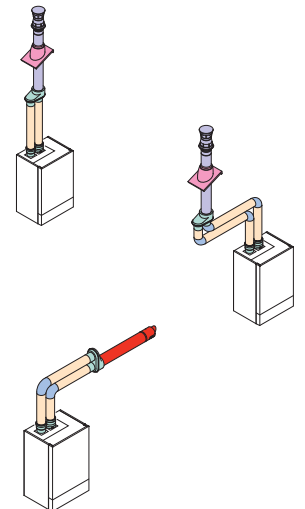

The Baxi Bermuda BBU HE is only suitable for use with the following flue kits:

Key	Item Description	Specification	OD Dimensions	Multifit Sales Code
	10m Concentric Flexible Flue	Complete with terminal	100mm	710143901
	12.5m Concentric Flexible Flue	Complete with terminal	100mm	710144001
	Flue Pull Cone*	Complete with terminal	100mm	720111801

\* The flue pull cone must be used for pulling the concentric flexible flue down the chimney. The flue pull cone can then be retained for future installations.

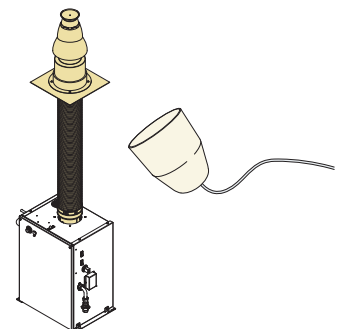

# Accessories



## Electro-mechanical Timer

An electro-mechanical 24 hour timer offering a selection of constantly on, constantly off or timed operation, with switching possible at 15 minute intervals using tappets set around an analogue clock for the utmost simplicity. *Standard Factory-Fitted in the Platinum Combi HE A. Optional in the Duo-tec Combi HE A.*



## Electronic Timer

An electronic 7 day timer with a digital LCD display, offering selection of multiple on/off switching operations over a 7 day period for maximum versatility. Also features an advance switch programme. *Optional.*



## Wireless Room Thermostat

A wireless programmable room thermostat which neatly minimises problems of compliance with Building Regulations Part L (Energy Conservation) & Part P (Electrical Safety). As simple to fit as it is to use. *Optional.*



## Multifit GasSaver

A flue gas recovery device designed to sit between the boiler and flue. The GasSaver recycles the heat from the flue gases which would normally be expelled into the atmosphere to preheat DHW. *Optional.*



## A Digital 7 Day Programmable Wall Mounted Room Thermostat

It incorporates a large blue back lit display and a simple mode selection knob for ease of use. *Optional.*

## Outdoor Weather Sensor

Outdoor Weather Sensors measure the temperature outside the building and vary the temperature of the water pumped into the heating systems accordingly. *Optional.*



Accessories	Multifit Sales Code
Stand Off Kit (facilitates vertical pipe runs, behind boiler)	5117035
24 hour Wireless Room Thermostat	5117391
Integral 7 day Electronic Timer	247207
Integral 24 hour Electro-mechanical Timer	247206
Multifit GasSaver	720056901
A Digital 7 Day Programmable Wall Mounted Room Thermostat	720030501
Outdoor Weather Sensor	720330001



# Low to zero carbon technologies

Climate change is now high on everyone's agenda, so we all need to think very carefully about how we use energy. The good news is, we've already been looking at alternative, renewable sources of energy for heating - and we have cleaner, greener heating system technology available right now.



## Baxi Solarflo™

### Solar Thermal Domestic Hot Water System

This system can use on-roof or in-roof solar panels or evacuated tubes to harness the Sun's solar energy and provide domestic hot water. It can provide on average 55%\* of a home's total hot water needs in summer.

\*Variable saving depending on type of solar system used, location and usage patterns.



## Baxi Ambiflo™

### Air Source Heat Pump

Baxi Ambiflo™ is an air to water heat pump, providing central heating for domestic properties. Baxi Ambiflo™ heat pumps are highly efficient, perfect for new developments and refurbishments



## Baxi Geoflo™

### Ground Source Heat Pump System

A Ground Source Heat Pump system taps into the natural heat found just metres below the Earth's surface. This stable, consistent energy is used to provide domestic underfloor heating.



## Baxi Biomass™

### Solid Fuel Heating

Baxi Biomass boilers use carbon neutral fuel such as pellets or logs from regenerated sources to provide sustainable and environmentally friendly heat for the home.



## Baxi CHP

### Combined Heat & Power

Generating electricity as well as heat, the Baxi Ecogen and Baxi DACHS mini-CHP are widely used as a more energy efficient way to heat and power buildings, with less reliance upon centralised power generation.



# An Introduction to Baxi Solarflo™



## Baxi Solarflo™ in-roof collector packages

In-Roof Slate	Baxi Code
1 Panel	5122245
2 Panels	5122246

In-Roof Tile	Baxi Code
1 Panel	5122271
2 Panels	5122272

The in-roof collectors are installed within the roof structure and are the perfect choice for all new build developments or for homeowners having roof refurbishments completed.



## Baxi Solarflo™ on-roof collector packages

On-Roof A Frame	Baxi Code
1 Panel	5122262
2 Panels	5122263
3 Panels	5122264

On-Roof Slate & Tile	Baxi Code
1 Panel	5122265
2 Panels	5122266
3 Panels	5122267

This collector is mounted above the slate/tile roof. They are ideal for homeowners who wish to install solar thermal domestic hot water to an existing building, without having to disturb too much of the roof structure. An A-frame option is also available for flat roof applications.



## Baxi Solarflo™ evacuated tube collector packages

On-roof Slate & Tile	Baxi Code
20 Tubes	5130214
30 Tubes	5130215

On-Roof A Frame	Baxi Code
20 Tubes	5130216
30 Tubes	5130217

Facade & Floor	Baxi Code
20 Tubes	5130232
30 Tubes	5130233

Equally suited for installation on new build developments and existing buildings. The collector is designed for on-roof application and is adaptable with both horizontal and vertical installations making it suitable for flat roof and facade applications such as gable end installations.

### Key features and benefits

- The complete solar package: panels, pump station, controller and all components required for safe installation
- High efficiency absorption rates on all flat plate and tube collectors
- Reduced installation time through plug and play mechanism and pre-wired pump station
- Integral controller that minimises installation time and maximises the solar efficiency of the system
- Integral air separator which enables the air to be vented at the pump station reducing installation time
- Pre-heat control that manages boiler or immersion heat input and minimises fuel consumption associated with water heating
- Solar gain measurement as standard
- Reduced commissioning time; adjustable flow meter with scale that maximises solar input through the panel
- Recommended with Heatrae Sadia's range of solar cylinders
- Industry leading warranties: 10 years for in-roof and on-roof panels, 5 years for evacuated tube collectors and 2 years on all components\*
- Peace of mind with national technical support and after sales advice from a single source

\*Subject to registration and annual service.



Baxi Ambiflo™ heat pumps are highly efficient and are one of the quietest in class. They are ideal for adequately insulated properties with underfloor heating or low temperature radiator systems, which have an outdoor area for siting the heat pump.

They are perfect for new developments, refurbishments and in some circumstances, retrofitting to existing systems.\*

### Key features & benefits:

- The Baxi Ambiflo™ is an outdoor heat only unit, ideal for central heating
- The one-piece heat pump has a closed and pre-charged refrigeration circuit – so there's no need for refrigerant handling during installation
- Designed for heating system temperatures between 25°C and 50°C, the Baxi Ambiflo™ can fulfil all the central heating needs of a domestic property down to low outside temperatures\*\*
- Suitable heat emitters include low temperature panel radiators, skirting radiators, fan convector radiators, underfloor heating or oversized high temperature panel radiators\*\*\*
- The Baxi Ambiflo™ air source heat pump is available in a choice of three nominal outputs 7.5kW, 9.0kW and 10.5kW
- Each model is supplied as part of a system pack containing the heat pump, an auxiliary 5kW electric heater, a programmable room thermostat, an outdoor sensor and flexible connection hoses. A system pack with buffer vessel is also available
- Intelligently controls any operation of the auxiliary electric heater (if necessary) during extremely low outdoor temperatures
- Baxi Ambiflo™ central heating systems are ideal for use with Baxi Solarflo™ domestic hot water systems, providing a total low carbon heating solution

\* With an upgrade to the heating system where necessary.

\*\* Please note that any use of the auxiliary electric heater will affect fuel bills.

\*\*\* Baxi only recommends the use of the Baxi Ambiflo™ with existing conventional radiators if the heat output of the lower system temperature can provide the necessary level of comfort (e.g. 20°C indoors) under peak load conditions (e.g. 0°C outside).

Ambiflo™ 75



Ambiflo™ 105



## What is it?

Baxi Geoflo is a ground source heat pump which makes use of energy stored within the earth to produce heating for the home.

## What is a suitable property for installation?

Ground source heat pumps are suitable for a wide range of properties, but are particularly suited to:

- Off mains gas properties that are land rich to enable them to accommodate ground arrays or outside urban areas to accommodate bore holes
- All new build and renovated buildings ranging from small houses, flats and apartments to schools, offices and spaces where low temperature heating is required
- Older buildings undergoing building fabric renovation requiring a new heating system
- Ideal replacement for direct electric heating such as storage heaters or oil fired heating systems in well insulated dwellings
- The heat pump is best suited to be installed on a ground floor and on an external wall (in a utility room or garage)

## How does it work?

Baxi Geoflo recovers low grade heat stored within the ground, from a depth of around 2 metres using buried pipework known as a ground array (or bore hole). This heat is passed through the unit and out into the heating system at a higher temperature. Just as a refrigerator extracts heat from food

and sends the heat out from the rear, Baxi Geoflo extracts heat from the ground which remains around 10°C all year round and transfers it into the heating system.

## Key features & benefits:

- Compact design - takes up minimal space in the home and is suitable for a range of property sizes
- Plug and play installation for simple and quick connection
- Pack includes ground array matched to the heat pump output to simplify specification
- Durable and reliable with a design life of 25 years and no annual service requirements reducing life time ownership costs
- Simple to install with no specialist installer training required
- Reduced running costs - heating bills can be reduced by up to 70%\* over alternative fuel sources
- Maximum efficiency and reduced running costs when installed with an underfloor heating system

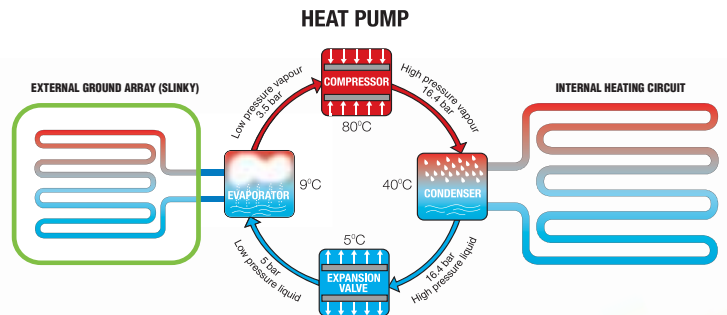



Baxi Biomass™ boilers use carbon neutral fuel such as pellets or logs from local, regenerated sources to provide sustainable and environmentally friendly heat for the home. The carbon released during the combustion process is balanced by that absorbed during the fuel's production. Baxi Biomass™ is ideal for those properties where mains gas is not available.

There are three solid fuel boilers in the range, Baxi Multi-heat™ – an automatically fed pellet boiler, Baxi Solo Innova™ – a log burning boiler, each with a choice of outputs and Baxi Bioflo™ – a fully featured central heating boiler.

## Key features & benefits Baxi Multi-heat™:

- Fuel storage integrated into boiler
- No heat storage tank required which means less space is required
- Simple operation via a digital control providing continuous variable heat output between 30-100%



## Key features & benefits Baxi Solo Innova™:

- Highly efficient (89 -91 %) minimising cost and emissions when running the unit
- Convenient top flue for ease of installation
- Delivered completely assembled



## Key features & benefits Baxi Bioflo™:

- 2 colour options available (granite and pearl)
- Carbon neutral heating solution = SAP benefit to the developer, up to 62% carbon saving benefit compared to a SEDBUK Band B listed boiler
- Integral fuel hopper, allowing storage of 3 days of fuel at a time
- Low fuel level indicator on control panel
- Modulating output 3.8-12kW
- Automatic ignition = No input required from the user to start the boiler. Can be directly connected to Heatrae or Santon Unvented cylinders. Eliminates the need to manually light the boiler
- Sealed system appliance. Can be linked with solar thermal hot water generation. Can be retrofitted to existing S & Y Plan systems





Baxi Ecogen heralds the most significant change in the home heating industry since the condensing boiler. That's because it is the first wall-hung, commercially available domestic micro combined heat and power (micro-CHP) appliance.

The Baxi Ecogen is a wall mounted combined heat and power appliance for the provision of central heating, hot water and electricity. It is as a practical alternative to a standard domestic boiler.

For heat generation, the basic principles are the same as a regular heat only boiler. The Baxi Ecogen can be used on standard S, W and Y plan open vented or sealed systems.

The Baxi Ecogen micro-CHP unit incorporates a free piston Stirling engine and supplementary burner providing heating, hot water and electricity from a single appliance.

This boiler has a maximum heat output of 24kW and maximum electrical output of 1kW. The Baxi Ecogen heat output can modulate down to 3.5kW (1:7 modulation ratio), generating

electricity throughout. This boiler is therefore suitable for a wide variety of properties and is available in both natural gas and LPG variants.

Also in the range is the Baxi DACHS™ mini CHP unit which is widely used as a more energy efficient way to heat and power buildings, with less reliance upon centralised power generation. The Baxi DACHS™ mini CHP is suitable for hotels, schools and multi-tenanted accommodation.

## Key features & benefits:

- Can offer substantial carbon and economic savings
- MCS certified therefore eligible for the Feed in Tariff scheme
- Displaces centrally generated electricity from the grid
- Simple installation
- User friendly, intelligent controls
- Easy replacement for existing boiler
- Can assist with Code for Sustainable Homes CO<sub>2</sub> targets.



# Support & Training

**heateam**  
The service division of Baxi Group

With call service support available 7 days a week, 363 days a year, **heateam** offers quick and effective servicing and maintenance support through over 280 highly trained heating experts across the country.

The Baxi trade technical helpline offers a range of free services to Baxi installers:

- In-warranty support
- Help with installation problems
- Boiler selection advice
- Fault-finding assistance
- Flue queries

## Training

We believe nothing compares to hands on training, so we always use live appliances to show how each product operates and its capabilities. And as well as Baxi products, our courses also cover generic combi boiler training, ACS and electronics. Most of these courses last a single day.

**heateam** achieved seventh place in the 2010 Top 50 Call Centres for Customer Service following the UK's biggest ever call centre benchmarking exercise.

The study was conducted by independent market research company GfK, who made 18,500 mystery shopper enquiries to the call centres to identify the best performers. Each call centre was rated, using over 50 criteria, on timeliness, ease of use, reliability, staff knowledge and personal service and awarded a customer service rating.

**heateam** has been given this award for the last two years showing on-going commitment to providing top class service to all its customers.



To enable national coverage, there are currently three centres of training excellence at Dartford, Warrington and Warwick, supported by energy efficiency courses at satellite centres across the UK. Arrangements can also be made for our trainers to hold courses at more suitable locations if necessary.

- Giving you the relevant product knowledge and encouraging best practice
- Helping you give homeowners the right advice and use it to sell better products and services
- Keeping you informed of the latest industry developments

For further information and details on our training courses, please visit [www.baxigrouptraining.co.uk](http://www.baxigrouptraining.co.uk)

# Contact us

For all enquiries please call  
**0844 871 1525**

email: [info@baxi.co.uk](mailto:info@baxi.co.uk)

visit: [www.baxi.co.uk](http://www.baxi.co.uk)

Open Monday - Friday, 8am - 6pm

Weekends & Bank Holidays, 8.30am - 2pm

We are closed on Christmas Day & New Year's Day

To book for a training course  
please call

**0845 600 7402**

Open Monday - Thursday, 8.30am - 5pm

Friday, 8.30am - 4.30pm

Please note calls may be monitored or recorded

# BAXI

Baxi, Brooks House,  
Coventry Road, Warwick, CV34 4LL.

[www.baxi.co.uk](http://www.baxi.co.uk)

PART OF BDR THERMEA

Range/Oct10/362067-06



This Brochure is printed on paper sourced from well managed forests and other controlled sources. This Brochure is printed using vegetable based inks. Please recycle this Brochure when you have finished with it.

Baxi policy is one of continual improvement and development. The right to change specification and appearance without prior notice is reserved. The reproduction of colours is as accurate as photographic and printing processes allow.

The consumer's statutory rights are not affected. e&oe